

XJP SERIES

Jacking Casters

XJP Series swivel casters combine the robust Revvo T Series 6" and 8" casters with a jacking mechanism to provide fast, easy and accurate vertical adjustment of working platforms, machines, and for other applications. Load capacities range from 1,177 lbs. for the rubber tire model to 2,200 for the Revvothane (Vulkollan®) tire. Both wheels have a durable cast-iron center.



Features & Dimensions

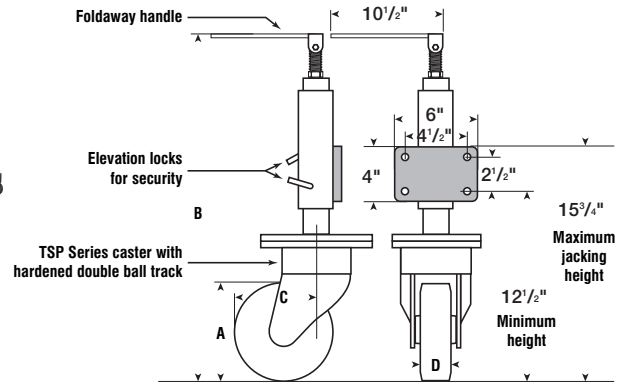

XJP plates have fixing holes to suit 1/2" diameter bolts.

A = Wheel Diameter B = Overall Height C = Swivel Radius D = Tread Width

XJP SERIES

A	B	C	D	Load Capacity	Bearing	Wheel	Swivel Part #
6"	23"	5-1/4"	1-3/4"	814	Precision Ball	Rubber Tire	XJP 150 RU2H
6"	23"	5-1/4"	2"	1760	Precision Ball	White Nylon	XJP 150 NY2H
6"	23"	5-1/4"	1-1/2"	1600	Precision Ball	Revvothane	XJP 150 PT2H
8"	25"	6-3/4"	2"	1177	Precision Ball	Rubber Tire	XJP 200 RU2H
8"	25"	6-3/4"	2"	2200	Precision Ball	White Nylon	XJP 200 NY2H
8"	25"	6-3/4"	1-3/4"	2200	Precision Ball	Revvothane	XJP 200 PT2H

FLOOR LOCKS

Revvo Floor Locks provide a positive means of instantly securing a truck or other mobile equipment in a fixed position without raising it. The mechanism bolts to the underside of the truck. Complete freedom of movement is restored by using the foot pedal.

Standard Top Plate

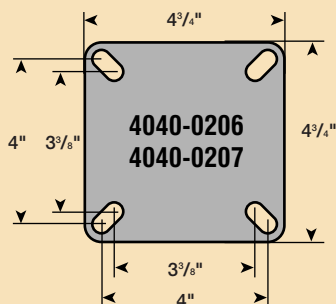

Floor Lock top plates have fixing holes to suit 3/8" diameter bolts.

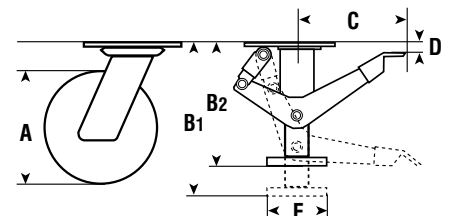
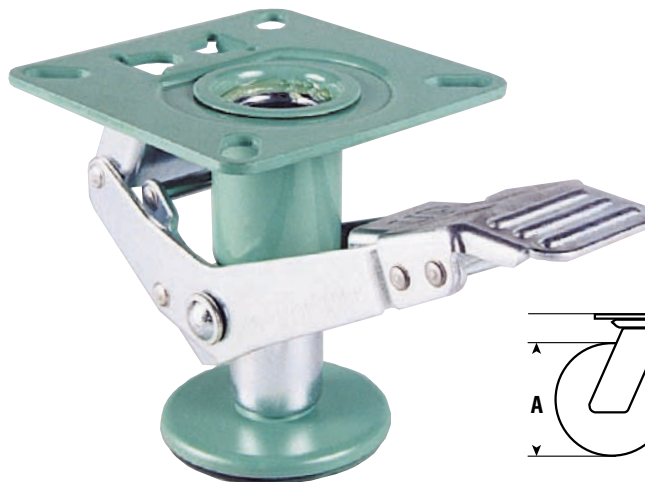

FLOOR LOCKS

A To Suit Caster With Wheel Diameter	B1 Mounting Height	B2 Retracted Height	C	D	E Floor Lock Diameter	Floor Lock Weight	Part #
4"	6"	5"	5-1/2"	1/4"	3-1/8"	4.40	4040-0206
6"	8-1/4"	6-11/16"	5-11/16"	5/16"	3-1/8"	4.40	4040-0207